



Quam

BB2
Beam Mount Speaker Assembly,
25/70.7V Transformer, Wire leads
BB2/70RS
Beam Mount Speaker Assembly,
70.7V Rotary Tap Select

01
LOUDSPEAKER ASSEMBLIES

0102- SURFACE MOUNTED SPEAKER SYSTEMS

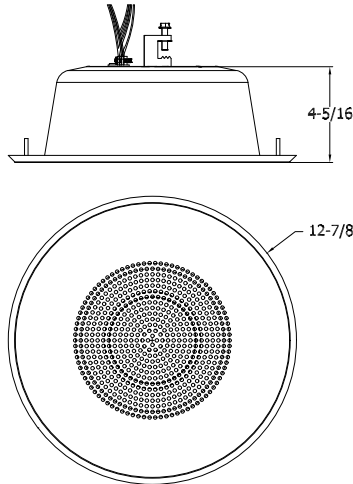

GENERAL DESCRIPTION

The Quam BB2/x is a beam mounted, complete loudspeaker assembly consisting of a steel baffle, 8" frame loudspeaker, transformer and steel back box with two beam clamps on 5.25" centers.

Finish Options: White or black baked epoxy hybrid.

INTENDED USE

Mounted to a steel "1" beam of 5.25" maximum width, downward firing in an indoor environment.

Program material: Signal tones, voice and music

COMPONENTS AND ORDER OPTIONS

Baffle	BR8WS
Loudspeaker	8C10PAX
Back Box	ERD8U, Round, 275 CID, UL Listed with 2-installed beam clamps
Transformer Options	All versions, 5 taps at -3 dB levels
5W,25V/70.7V pig-tail	Order as: BB2
4W,70.7V Rotary Select	Order as: BB2/70RS
Finish Options*:	Order as: BB2/B or BB2/B/70RS

*Black only

AUDIO SPECIFICATIONS

Speaker Size	8" frame
Average Sensitivity	95 dB SPL, 1W/ 1M
Loudspeaker Power Rating	20W RMS, EIA 426A Standard
Calculated Maximum System Output	BB2- 102dB SPL, 5W/ 1M BB2/70RS- 101 dB-SPL, 4W/1M
Magnet Type, Weight	BeFe Ceramic, 10 oz. Nominal
Frequency Response	65Hz - 17 kHz EIA 462A Standard
Nominal Coverage Angle	90° Included angle, -6 dB / 2 kHz, Half space
Audio Connection	7" color-coded pigtails, pre-cut, 0.75" diameter cable clamp

Recommended construction sequences, installation instructions and A&E Specifications are available in various formats on the Quam Architects' and Engineers' Resources CD or on the web at: www.quamspeakers.com

Quam-Nichols Company

234 East Marquette Road, Chicago, IL 60637
Phone: (800) NEED NOW Fax: (888) NEED NOW
(800) 633 - 3669 (888) 633 - 3669
E-Mail: neednow@qnc.com www.quamspeakers.com

