



Quam

SYSTEM 1 Wall Mount, Square, White

01
LOUDSPEAKER ASSEMBLIES

0102 - SURFACE MOUNTED SPEAKER SYSTEM

WIREMOLD
KNOCKOUT *2
TOP AND BOTTOM

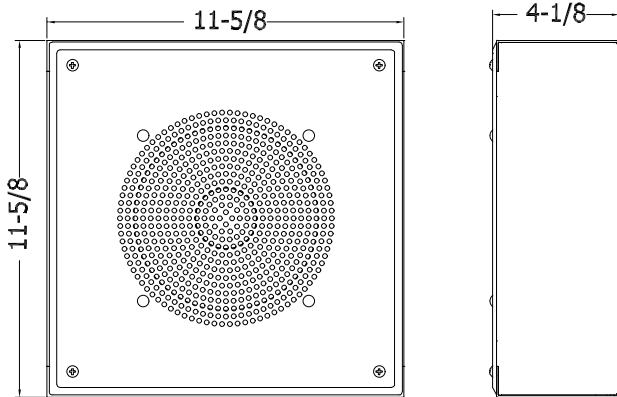

GENERAL DESCRIPTION

The QUAM SYSTEM 1 is a complete loudspeaker assembly with an industry standard 8" O.D., full range speaker, 5W- 25/70.7V pigtail transformer, 22 gage steel baffle and 16 gage square steel enclosure.
Finish: White baked epoxy hybrid.

INTENDED USE

Indoor environment
Program Material: Signal tones, voice and music

SYSTEM COMPONENTS

| | |
|-------------|------------------------------|
| Loudspeaker | 8C5PAX |
| Transformer | 5W*, 25/70.7V pigtail (TBLU) |
| Baffle | BS8W |
| Enclosure | SE1WVP |

* 5W, 2.5W, 1.25W, 0.63W, 0.31W

AUDIO SPECIFICATIONS

| | |
|----------------------------------|---|
| Average Sensitivity | 92dB SPL, 1W/ 1M |
| Loudspeaker Power Rating | 12W RMS, EIA 426A Standard |
| Calculated Maximum System Output | 99 dB SPL, 5W/ 1M |
| Magnet Type, Weight | BeFe Ceramic, 4.8 oz. Nominal |
| Frequency Response Nominal | 65 Hz - 17 kHz EIA 462A Standard |
| Coverage Angle | 90° Included Angle, -6 dB / 2 kHz, Half space |
| Audio Connection | 7" color-coded pigtails, pre-cut |

Recommended construction sequences, installation instructions and A&E Specifications are available in various formats on the Quam Architects' and Engineers' Resources CD or on the web at: www.quamspeakers.com

Quam-Nichols Company

234 East Marquette Road, Chicago, IL 60637
Phone: (800) NEED NOW Fax: (888) NEED NOW
(800) 633 - 3669 (888) 633 - 3669
E-Mail: neednow@qnc.com www.quamspeakers.com

