



# Quam

## SYSTEM 10/VC

Compact, Shallow, Wall Mount Loudspeaker

01 LOUDSPEAKER ASSEMBLIES

### 0102 - SURFACE MOUNTED SPEAKER SYSTEMS

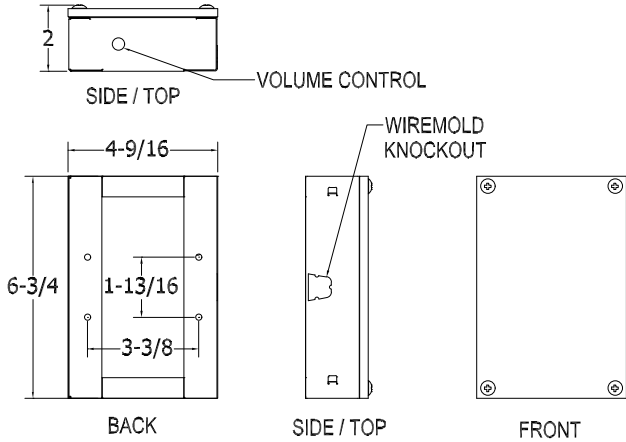

#### GENERAL DESCRIPTION

The Quam SYSTEM 10 is a complete loudspeaker assembly with 4" frame loudspeaker, 25 and 70.7V universal transformer, charcoal gray cloth baffle and CRS enclosure. Finish: Black baked epoxy hybrid.

#### INTENDED USE

Indoor environment, surface mount  
Program Material: Signal tones and voice

#### SYSTEM COMPONENTS

Loudspeaker	4C3PA
Transformer	TBLU- 5W, 25 and 70.7V 5 taps at -3 dB levels
Enclosure	SYSTEM 10/VC
Attenuator	Model VC- Continuous

#### RECOMMENDED ADDITIONAL QUAM COMPONENTS

N/A

#### AUDIO SPECIFICATIONS

Speaker Size	4" frame
Average Sensitivity	96 dB SPL, 1W/ 1M
Loudspeaker Power Rating	10W RMS, EIA 426A Standard
Calculated Maximum System Output	103 dB SPL, 5W/ 1M
Frequency Response	180 Hz - 10 kHz EIA 462A Standard
Nominal Coverage Angle	90° Included Angle, -6 dB / 2 kHz, Half space
Audio Connection	7" color-coded pigtails, pre-cut

Recommended construction sequences, installation instructions and A&E Specifications are available in various formats on the Quam Architects' and Engineers' Resources CD or on the web at: [www.quamspeakers.com](http://www.quamspeakers.com)

#### Quam-Nichols Company

234 East Marquette Road, Chicago, IL 60637  
Phone: (800) NEED NOW Fax: (888) NEED NOW  
(800) 633 - 3669 (888) 633 - 3669  
E-Mail: [neednow@qnc.com](mailto:neednow@qnc.com) [www.quamspeakers.com](http://www.quamspeakers.com)

