



Quam

SYSTEM 1VP

Wall Mount, Square, White

SYSTEM 2VP

Wall Mount, Slanted, White

060 I – VANDAL RESISTANT SPEAKER ASSEMBLIES

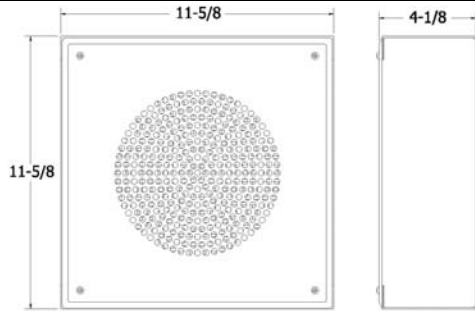

SYSTEM 1VP

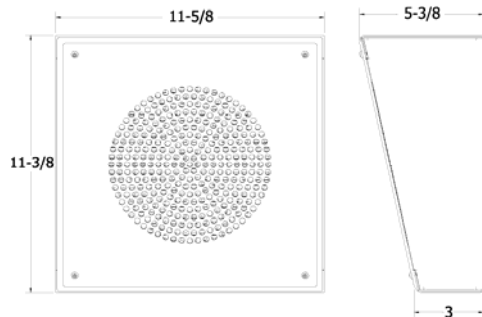

SYSTEM 2VP



SYSTEM 2VP SHOWN

GENERAL DESCRIPTION

The Quam SYSTEM 1VP is a complete loudspeaker assembly, with 8" frame loudspeaker, 25/70.7V universal transformer, 16 gage square steel enclosure and baffle with #8-32 'pin-in-hex' hardware. Finish: White baked epoxy hybrid.

GENERAL DESCRIPTION

The Quam SYSTEM 2VP is a complete loudspeaker assembly, with 8" frame loudspeaker, 25/70.7V universal transformer, 16 gage slanted steel enclosure and baffle with #8-32 'pin-in-hex' hardware. Finish: White baked epoxy hybrid.

INTENDED USE

Both variants: Protected outdoor or indoor environments
SYSTEM 1VP: Vertical or horizontal surface mount
SYSTEM 2VP: Vertical surface mount, downward firing
Program Material: Signal tones, voice and music

SYSTEM COMPONENTS

Loudspeaker	8C10PAOT
Transformer	TBLU-5W, 25 and 70.7V, 5 taps at -3 dB levels
Enclosure	
SYSTEM 1VP	SE1WVP
SYSTEM 2VP	SE2WVP
Baffle	BS8VP

RECOMMENDED ADDITIONAL QUAM COMPONENTS

N/A

AUDIO SPECIFICATIONS

Speaker Size	8" frame
Average Sensitivity	97 dB SPL, 1W/ 1M
Loudspeaker Power Rating	20W RMS, EIA 426A Standard
Calculated Output	103dB SPL, 4W/ 1M
Magnet Type, Weight	BeFe Ceramic, 10 oz. Nominal
Frequency Response	60Hz - 17 kHz EIA 462A Standard
Nominal Coverage Angle	100° Included Angle, -6 dB / 2 kHz, Half space
Audio Connection	7" color-coded pigtails, pre-cut

Recommended construction sequences, installation instructions and A&E Specifications are available in various formats on the Quam Architects' and Engineers' Resources CD or on the web at: www.quamspeakers.com

06 CORRECTION / DETENTION

Quam-Nichols Company

234 East Marquette Road, Chicago, IL 60637
Phone: (800) NEED NOW Fax: (888) NEED NOW
(800) 633 - 3669 (888) 633 - 3669
E-Mail: neednow@qnc.com www.quamspeakers.com

