

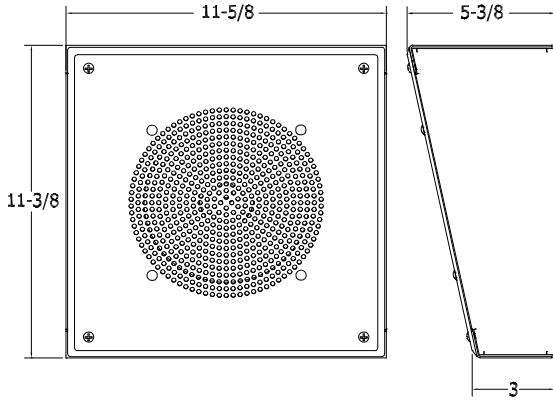

SYSTEM 2

Wall Mount, Slanted, White

0102 - SURFACE MOUNTED SPEAKER SYSTEM



01 LOUDSPEAKER ASSEMBLIES

GENERAL DESCRIPTION

The Quam SYSTEM 2 is a complete loudspeaker assembly with 8" frame loudspeaker, 25 and 70.7V universal transformer, 16 gage slanted steel enclosure and 22 gage baffle.

Finish: White baked epoxy hybrid.

INTENDED USE

Indoor environment
 Vertical surface mount, downward firing
 Program Material: Signal tones, voice and music

SYSTEM COMPONENTS

Loudspeaker	8C5PAX
Transformer	TBLU- 5W, 25 and 70.7V 5 taps at -3 dB levels
Enclosure	SYSTEM 2- SE2WVP
Baffle	BS8W

* 5W, 2.5W, 1.25W, 0.63W, 0.32W

AUDIO SPECIFICATIONS

Speaker Size	8" frame
Average Sensitivity	92 dB SPL, 1W/ 1M
Loudspeaker Power Rating	12W RMS, EIA 426A Standard
Calculated Maximum System Output	99 dB SPL, 5W/ 1M
Magnet Type, Weight	BeFe Ceramic, 4.8 oz. Nominal
Frequency Response	65 Hz - 17 kHz EIA 462A Standard
Nominal Coverage Angle	90° Included Angle, -6 dB / 2 kHz, Half space
Audio Connection	7" color-coded pigtailed, pre-cut

Recommended construction sequences, installation instructions and A&E Specifications are available in various formats on the Quam Architects' and Engineers' Resources CD or on the web at: www.quamspeakers.com

Quam-Nichols Company

234 East Marquette Road, Chicago, IL 60637
 Phone: (800) NEED NOW Fax: (888) NEED NOW
 (800) 633 - 3669 (888) 633 - 3669
 E-Mail: neednow@qnc.com www.quamspeakers.com

