



Quam

SYSTEM 7DT Drive-Thru Menu Board Loudspeaker

01
LOUDSPEAKER ASSEMBLIES

0102 - SURFACE MOUNTED SPEAKER SYSTEMS

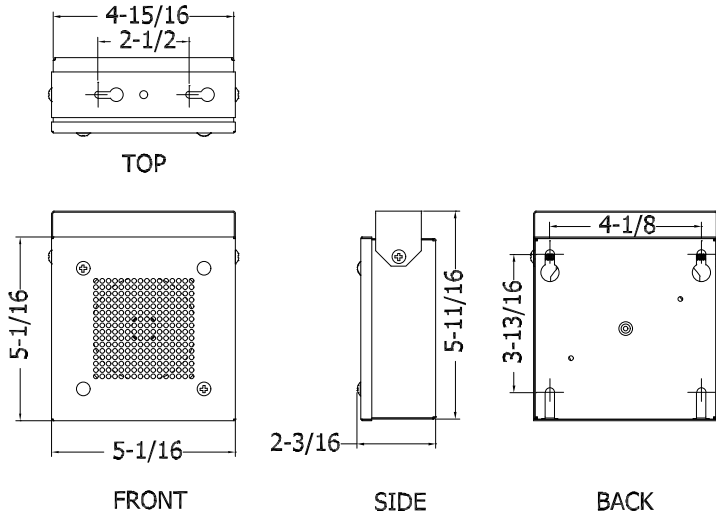

GENERAL DESCRIPTION

The QUAM SYSTEM 7DT is a complete menu board loudspeaker assembly with a 4" O.D. speaker, 22 gage steel baffle and enclosure. Nominal impedance is 8-Ohms.

Finish: Black baked epoxy hybrid.

INTENDED USE

Indoor or protected outdoor environment, Drive-thru menu board, vertical surface mount.

Program Material: Signal tones and voice

SYSTEM COMPONENTS

Loudspeaker	4C3Z80T
-------------	---------

AUDIO SPECIFICATIONS

Average Sensitivity	91dB SPL, 1W/ 1M
Loudspeaker Power Rating	10W RMS, EIA 426A Standard
Calculated Output	101dB SPL, 4W/ 1M
Frequency Response	130Hz - 9 kHz EIA 462A Standard
Nominal Coverage Angle	90° Included Angle, -6 dB / 2 kHz, Half space
Audio Connection	15" color-coded pigtailed, pre-cut

Recommended construction sequences, installation instructions and A&E Specifications are available in various formats on the Quam Architects' and Engineers' Resources CD or on the web at: www.QuamSpeakers.com

Quam-Nichols Company

234 East Marquette Road, Chicago, IL 60637
Phone: (800) NEED NOW Fax: (888) NEED NOW
(800) 633 - 3669 (888) 633 - 3669
E-Mail: neednow@qnc.com www.quamspeakers.com

