



Quam

SYSTEM 9/VC Wall or Corner Mount Loudspeaker

01
LOUDSPEAKER ASSEMBLIES

0102 - SURFACE MOUNTED SPEAKER SYSTEMS

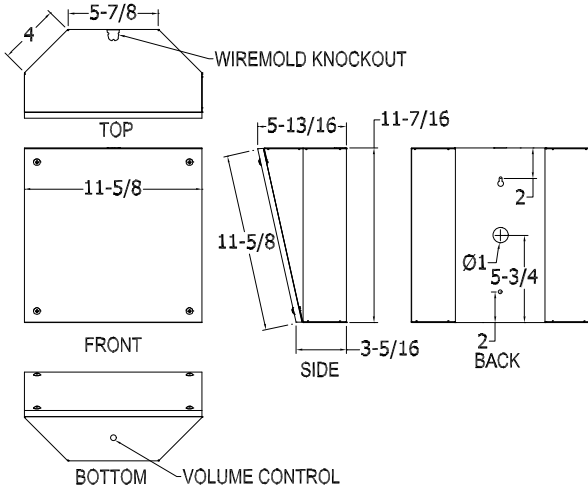

GENERAL DESCRIPTION

The Quam SYSTEM 9/VC is a complete loudspeaker assembly with 8" frame loudspeaker, 25 and 70.7V universal transformer, volume control, charcoal gray cloth baffle and steel enclosure. Finish: Black baked epoxy hybrid.

INTENDED USE

Indoor environment, vertical surface mount, wall or corner position, downward firing.

Program Material: Signal tones, voice and music

SYSTEM COMPONENTS

| | |
|-------------|-----------------------------------|
| Loudspeaker | 8C5PAX |
| Transformer | TBLU - 5W, 5 taps at -3 dB levels |
| Enclosure | SYSTEM 9/VC |
| Attenuator | Model VC - Continuous Attenuator |

RECOMMENDED ADDITIONAL QUAM COMPONENTS

N/A

AUDIO SPECIFICATIONS

| | |
|----------------------------------|--|
| Speaker Size | 8" frame |
| Average Sensitivity | 92 dB SPL, 1W/ 1M |
| Loudspeaker Power Rating | 12W RMS, EIA 426A Standard |
| Calculated Maximum System Output | 99 dB SPL, 5W/ 1M |
| Magnet Type, Weight | BeFe Ceramic, 4.8 oz. Nominal |
| Frequency Response | 65Hz - 17 kHz EIA 462A Standard |
| Nominal Coverage Angle | 100° Included Angle, -6 dB / 2 kHz, Half space |
| Audio Connection | 7" color-coded pigtails, pre-cut |

Recommended construction sequences, installation instructions and A&E Specifications are available in various formats on the Quam Architects' and Engineers' Resources CD or on the web at: www.quamspeakers.com

Quam-Nichols Company

234 East Marquette Road, Chicago, IL 60637
Phone: (800) NEED NOW Fax: (888) NEED NOW
(800) 633 - 3669 (888) 633 - 3669
E-Mail: neednow@qnc.com www.quamspeakers.com

