

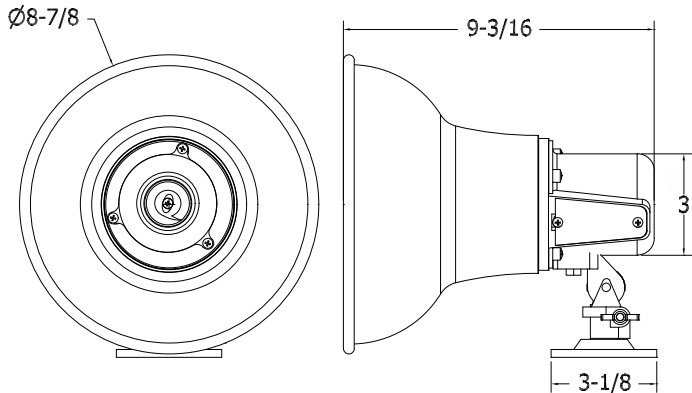

Quam

QH16T Paging Horn with Universal Mount

0103 - PAGING HORN



01

LOUDSPEAKER ASSEMBLIES

GENERAL DESCRIPTION

The Quam QH16T is a weatherproof loudspeaker assembly with double re-entrant horn, compression type driver, 25V and 70.7V universal transformer and adjustable, universal mounting flange.
Finish: Tan enamel

INTENDED USE

Outdoor or indoor environment, vertical or horizontal surface mount; adapts to pole mount
Program Material: Voice and signal tone

SYSTEM COMPONENTS

Loudspeaker:	QH16T
Transformer:	25V/ 70.7V, 16W, Integral to unit 5 taps at -3dB levels*

* 16W, 8W, 4W, 2W, 1W

AUDIO SPECIFICATIONS

Speaker Type	Compression, re-entrant horn
Average Sensitivity	110 dB-SPL, 1W/ 1M
Power rating	16W-RMS, EIA 426A Standard
Calculated Maximum System Output	121 dB-SPL, 16W / 1M
Frequency Response	300 - 15 kHz EIA 426A Standard
Nominal Coverage Angle	110° Included angle, -6dB 2 kHz
Transformer Tap Selection	Selector switch
Audio Connection	Binding Screw

Recommended construction sequences, installation instructions and A&E Specifications are available in various formats on the Quam Architects' and Engineers' Resources CD or on the web at: www.quamspeakers.com

Quam-Nichols Company

234 East Marquette Road, Chicago, IL 60637
Phone: (800) NEED NOW Fax: (888) NEED NOW
(800) 633 - 3669 (888) 633 - 3669
E-Mail: neednow@qnc.com www.quamspeakers.com

© 2009 Quam-Nichols Company Quam-Nichols reserves the right to make changes and/or improvements to its products at any time and without notice.



TQH16T_09MR30