



Quam

C10FX/H70/Q2

Ceiling Mounted Speaker Assembly
Gypsum Board or Ceiling Tile Mount

01
LOUDSPEAKER ASSEMBLIES

0104.3.1 - SPEAKER, TRANSFORMER, BAFFLE, QMOUNT

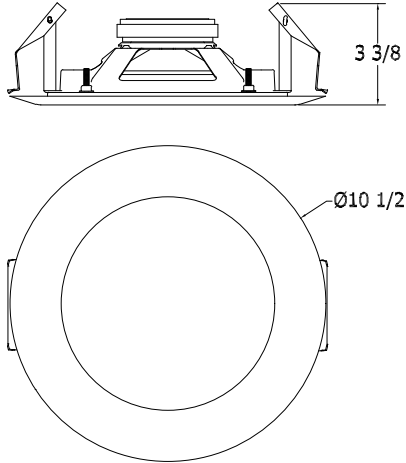

GENERAL DESCRIPTION

The QUAM C10FX/H70/Q2 is a complete loudspeaker assembly with a 8" O.D. full range speaker, 10W-70.7V, low loss, extended frequency response pigtail transformer and 2-piece designer steel baffle with QMount™ installation system.

Finish: Baffle, white baked epoxy hybrid,
Loudspeaker, black baked epoxy hybrid.

INTENDED USE

Indoor environment, mounted parallel to floor plane in either blind-mount in 5/8" gypsum board ceiling or conventional 24" x 24" (or larger) ceiling tile up to 5/8" thick.
Program Material: Signal tones, voice and music

SYSTEM COMPONENTS

Loudspeaker	8C10FEPAX
Transformer	10W*, 70.7V, pigtail select (TCH70)
Baffle	Q2
Installation System	QMount™

* 10W, 5W, 2.5W, 1.25W, 0.63W

AUDIO SPECIFICATIONS

Average Sensitivity	95 dB SPL, 1W/ 1M
Loudspeaker Power Rating	20W RMS, EIA 426A Standard
Calculated Output	105dB SPL, 10W/ 1M
Magnet Type, Weight	BeFe Ceramic, 10 oz. Nominal
Frequency Response	40Hz - 18 kHz EIA 426A Standard
Nominal Coverage Angle	100° Included Angle, -6 dB / 2 kHz, Half space
Audio Connection	7" color-coded pigtails, pre-cut

Recommended construction sequences, installation instructions and A&E Specifications are available in various formats in the Quam Architects' and Engineers' Resources section on the web at: www.QuamSpeakers.com

RECOMMENDED ADDITIONAL QUAM COMPONENTS

Ceiling tile application requires use of QUAM SSB9 Tile Bridge

Quam-Nichols Company

234 East Marquette Road, Chicago, IL 60637
Phone: (800) NEED NOW Fax: (888) NEED NOW
(800) 633 - 3669 (888) 633 - 3669
E-Mail: neednow@qnc.com www.quamspeakers.com

