

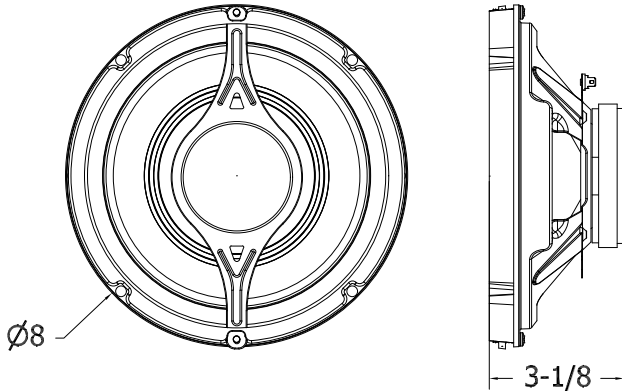

# Quam

## 8C10FECO 8" CoAxial Loudspeaker With Foam Surround

**0201 - LOUDSPEAKER, INDIVIDUAL, COAXIAL**



### GENERAL DESCRIPTION

The Quam 8C10FECO is an 8" frame, 8 Ohm loudspeaker with foam surround and coaxial mount piezoelectric ceramic HF.

Finish: Black baked epoxy hybrid.

### INTENDED USE

Wide frequency response replacement loudspeaker or combined with recommended Quam components to form a complete loudspeaker system; indoor environment.

Program Material: Signal tones, voice and music

### SYSTEM COMPONENTS

N/A

### RECOMMENDED ADDITIONAL QUAM COMPONENTS

Refer to Section 0104.6 - Customer Specified Assembly or individual components listed below:

0502 - Transformers

0301 - Baffles, Round  
OR

0302 - Baffles, Square

0401.1 - Flush Mounted Back Boxes, Round  
OR

0401.2 - Flush Mounted Back Boxes, Square

0402 - Loudspeaker Mounting Devices

### AUDIO SPECIFICATIONS

Speaker Size	8" Frame
Average Sensitivity	95 dB SPL, 1W / 1M
Power Rating	20W RMS, EIA 426A Standard
Calculated Output	108 dB SPL, 20W / 1M
Frequency Response	40 Hz - 20 kHz EIA 426A Standard
Nominal Coverage Angle	90° Included Angle, -6 dB / 2 kHz, Half Space
Mounting	4x 1/4" Holes Spaced 90° Apart on 7-5/8" Circle
Audio Connection	0.205" Spade Lug

Recommended construction sequences, installation instructions and A&E Specifications are available in various formats on the Quam Architects' and Engineers' Resources CD or on the web at: [www.quamspeakers.com](http://www.quamspeakers.com)

### Quam-Nichols Company

234 East Marquette Road, Chicago, IL 60637  
Phone: (800) NEED NOW Fax: (888) NEED NOW  
(800) 633 - 3669 (888) 633 - 3669  
E-Mail: [neednow@qnc.com](mailto:neednow@qnc.com) [www.quamspeakers.com](http://www.quamspeakers.com)



**02**  
**LOUDSPEAKERS, INDIVIDUAL**