



Quam

8C10DVPAX 8" Dual Voice Coil Loudspeaker

02

LOUDSPEAKERS, INDIVIDUAL

0202 - LOUDSPEAKER, INDIVIDUAL, DUAL VOICE COIL

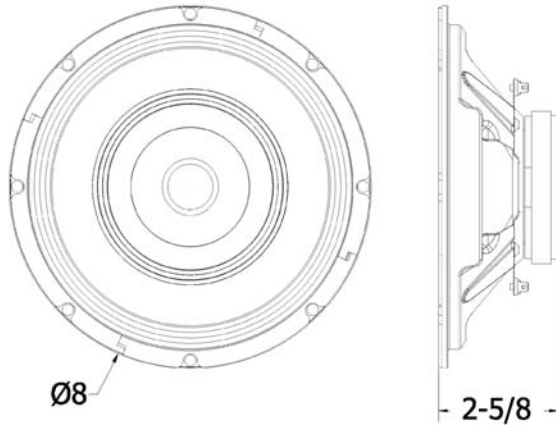

GENERAL DESCRIPTION

The Quam 8C10DVPAX is an 8" frame loudspeaker with concentric mount hard fiber HF cone and two discrete 8 Ohm voice coils. Finish: Black baked epoxy hybrid.

INTENDED USE

Replacement loudspeaker that can reproduce sound from two independent audio signals or combined with recommended Quam components to form a complete loudspeaker system; indoor environment.

Program Material: Signal tones, voice and music

RECOMMENDED ADDITIONAL QUAM COMPONENTS

Refer to Section 0104.6 - Customer Specified Assembly or individual components listed below:

0502- Transformers, may require two depending on use

0301- Baffles, Round -or-

0302- Baffles, Square

0401.1- Flush Mounted Back Boxes, Round -or-

0401.2 Flush Mounted Back Boxes, Square

0402- Loudspeaker Mounting Devices

AUDIO SPECIFICATIONS

Speaker Size	8" frame
Average Sensitivity	92 dB SPL, 1W/ 1M
Power Rating	15W RMS, EIA 426A Standard
Calculated Output	105 dB SPL, 20W/ 1M
Magnet Type, Weight	BeFe Ceramic, 10 oz. Nominal
Frequency Response	60Hz - 12 kHz EIA 462A Standard
Nominal Coverage Angle	100° Included Angle, -6 dB / 2 kHz, Half space
Mounting	8x 1/4" holes spaced 45° apart on 7-5/8" circle
Audio Connections	0.205" Spade lug, two locations

Recommended construction sequences, installation instructions and A&E Specifications are available in various formats on the Quam Architects' and Engineers' Resources CD or on the web at: www.quamspeakers.com

Quam-Nichols Company

234 East Marquette Road, Chicago, IL 60637
Phone: (800) NEED NOW Fax: (888) NEED NOW
(800) 633 - 3669 (888) 633 - 3669

E-Mail: neednow@qnc.com www.quamspeakers.com

© 2009 Quam-Nichols Company Quam-Nichols reserves the right to make changes and/or improvements to its products at any time and without notice.



T8C10PAX_09MY08