



Quam

4C3PA
0203, Loudspeaker, Individual

BR4WS
0301.1, Screw Mount Baffle

02
LOUDSPEAKERS, INDIVIDUAL

0203 - LOUDSPEAKER, INDIVIDUAL

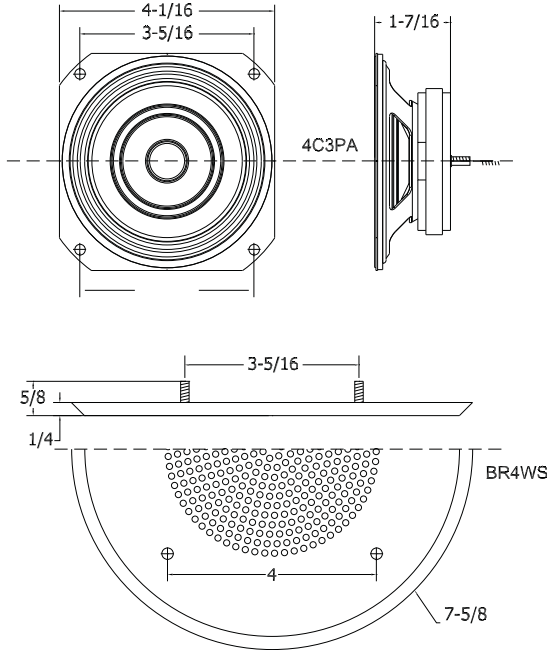

GENERAL DESCRIPTION

The Quam 4C3PA is a 4" square frame, 8 Ohm loudspeaker with cloth surround. Finish: Black baked hybrid epoxy.

INTENDED USE

Wide frequency response replacement loudspeaker or combined with recommended Quam components to form a complete loudspeaker assembly; indoor environment.

Program Material: Signal tones, voice and music

SYSTEM COMPONENTS

N/A

RECOMMENDED ADDITIONAL QUAM COMPONENTS

Section 0301.1 - Baffle, Stud Mount, BR4WS (shown above)

Section 0401.1 - Back Box, Flush Mounted, Round, All

Section 0402 - Loudspeaker Mounting Device, SSB-4

Section 0502 - Transformer, All

AUDIO SPECIFICATIONS

Speaker Size	4" Frame
Average Sensitivity	96 dB SPL, 1W / 1M
Power Rating	10W RMS, EIA 426A Std.
Calculated Output	107 dB SPL, 10W / 1M
Frequency Response	80 Hz - 10 kHz EIA 426A Std.
Nominal Coverage Angle	90° Included Angle, -6 dB / 2 kHz, Half Space
Mounting	4x 1/4" Holes Spaced 90° Apart on 4-11/16" Circle
Audio Connection	0.205" Spade Lug

Recommended construction sequences, installation instructions and A&E Specifications are available in various formats on the Quam Architects' and Engineers' Resources CD or on the web at: www.quamspeakers.com

Quam-Nichols Company

234 East Marquette Road, Chicago, IL 60637
Phone: (800) NEED NOW Fax: (888) NEED NOW
(800) 633 - 3669 (888) 633 - 3669
E-Mail: neednow@qnc.com www.quamspeakers.com

