

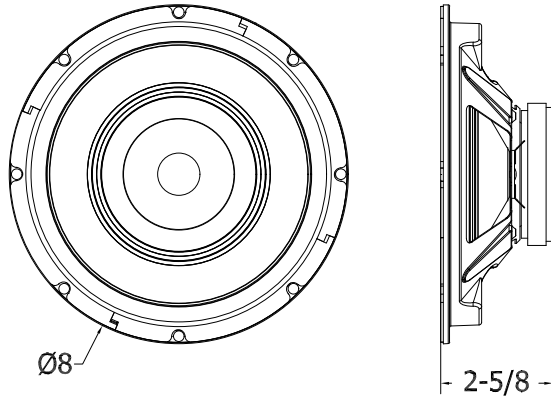

Quam

8C10FEPAX 8" Dual Cone Loudspeaker

0203 - LOUDSPEAKER, INDIVIDUAL



02

LOUDSPEAKERS, INDIVIDUAL

GENERAL DESCRIPTION

The Quam 8C10FEPAX is an 8" frame, 8 Ohm loudspeaker with urethane foam surround and concentric mount hard fiber HF cone.

Finish: Black baked epoxy hybrid.

INTENDED USE

Wide frequency response replacement loudspeaker or combined with recommended Quam components to form a complete loudspeaker system; indoor environment.

Program Material: Signal tones, voice and music

SYSTEM COMPONENTS

N/A

RECOMMENDED ADDITIONAL QUAM COMPONENTS

Refer to Section 0104.6 - Customer Specified Assembly or individual components listed below:

0502 - Transformers

0301 - Baffles, Round

OR

0302 - Baffles, Square

0401.1 - Flush Mounted Back Boxes, Round

OR

0401.2 - Flush Mounted Back Boxes, Square

0402 - Loudspeaker Mounting Devices

AUDIO SPECIFICATIONS

Speaker Size	8" Frame
Average Sensitivity	95dB SPL, 1W / 1M
Power Rating	20W RMS, EIA 426A Standard
Calculated Output	108dB SPL, 20W / 1M
Frequency Response	40 Hz - 18 kHz EIA 426A Standard
Nominal Coverage Angle	90° Included Angle, -6 dB / 2 kHz, Half Space
Mounting	4x 3/8" Holes Spaced 90° Apart on 7-5/8" Circle
Audio Connection	0.205" Spade Lug

Recommended construction sequences, installation instructions and A&E Specifications are available in various formats on the Quam Architects' and Engineers' Resources CD or on the web at: www.quamspeakers.com

Quam-Nichols Company

234 East Marquette Road, Chicago, IL 60637

Phone: (800) NEED NOW Fax: (888) NEED NOW

(800) 633 - 3669

(888) 633 - 3669

E-Mail: neednow@qnc.com

www.quamspeakers.com

