



Quam

SSB-I 900

Mounting Device with
18.0 CID Electrical Junction Box

SSB-I 900DEEP

Mounting Device with
30.3 CID Electrical Junction Box

0402 - MOUNTING DEVICES

04 BACK BOXES / MOUNTING DEVICES

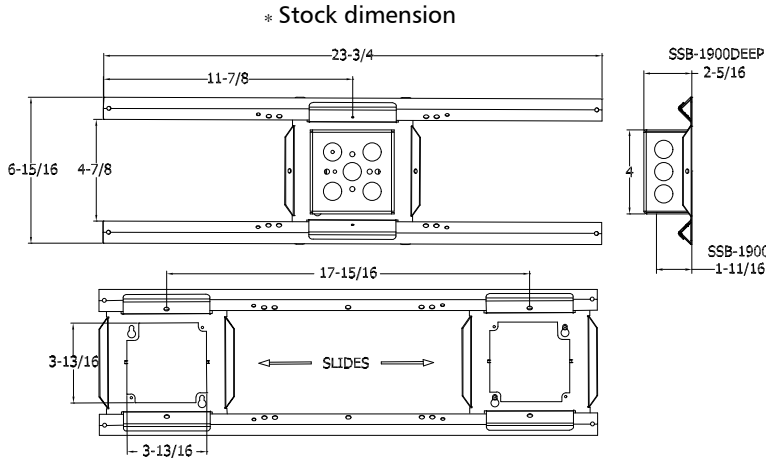

GENERAL DESCRIPTION

The Quam SSB-1900 is a rust resistant steel, adjustable load bearing support with a medium depth, 18.0 CID steel '1900' electrical junction box.

The Quam SSB-1900DEEP is a rust resistant steel, adjustable load bearing support with a 30.3 CID steel '1900' electrical junction box.

INTENDED USE

Parallel to floor plane in a suspended ceiling structure; maximum span of 24" in one dimension; indoor environment.

WARNING! NOT TO BE USED FOR FANS OR AIR-MOVERS OF ANY TYPE.

When used with devices that rotate, such as dome video cameras, the SSB-1900 must be secured to the ceiling grid; a secondary, independent tie-off must be used for the device itself.

JUNCTION BOX ACCESS

All 4 vertical sides	2x 1/2" k/o conduit
	1x 1/2"/ 3/4" eccentric k/o conduit
Top Horizontal Surface	3 x 1/2" k/o conduit (SSB-1900)
	2 x 1/2" k/o conduit (SSB-1900DEEP)
	2x 1/2"/ 3/4" eccentric k/o conduit

MECHANICAL ATTACHMENT

Bottom Horizontal Surface	2x 8-32 PEM nuts to attach 2-gang adapter plate if required
Tie-offs	4x Total, 1 each at end of bridge rail 2x Terminal plate

Recommended construction sequences, installation instructions and A&E Specifications are available in various formats on the Quam Architects' and Engineers' Resources CD or on the web at: www.quamspeakers.com

* 23-3/4" Stock dimension, lengths up to 48" available as a special order, please contact Factory for delivery and pricing

Quam-Nichols Company

234 East Marquette Road, Chicago, IL 60637
Phone: (800) NEED NOW Fax: (888) NEED NOW
(800) 633 - 3669 (888) 633 - 3669
E-Mail: neednow@qnc.com www.quamspeakers.com

