



Quam

QC20

Ten-Step Attenuator With Terminal Block Connector

0501 - ATTENUATORS

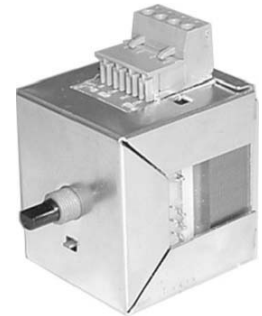
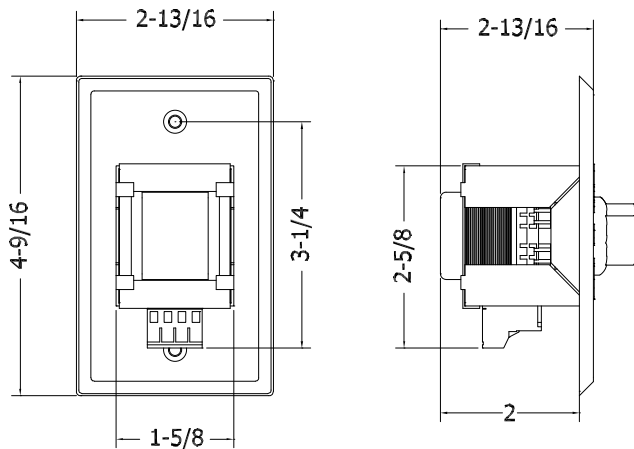

Connector located
On BOTTOM
of device

GENERAL DESCRIPTION

The Quam QC20 is a single gang, continuous rotary, ten-step audio level attenuator with an OFF position.

Faceplate Finish: Brushed stainless steel, embossed positions

Knob Black with white indicator

INTENDED USE

Attenuates audio power to any number of loudspeakers up to 20W load. For use with 25V or 70.7V distributed audio systems; indoor environment.

Program Material: Signal tones, voice and music

RECOMMENDED ADDITIONAL QUAM COMPONENTS

0403 - Surface Mounting Devices
SE4W Single Gang Box

AUDIO SPECIFICATIONS

Power Rating	20W continuous
Attenuation (Ref: 25V,70.7V line)	Position 10, Full signal Positions 9-3, -3 dB per step Positions 2-1, -6 dB per step Position 0, -36 dB
Insertion Loss	< 0.5 dB

MECHANICAL SPECIFICATIONS

Mounting	Single gang electrical box, 2-1/8" D
Audio Connection	4-pin terminal block

Recommended construction sequences, installation instructions and A&E Specifications are available in various formats on the Quam Architects' and Engineers' Resources CD or on the web at: www.quamspeakers.com

05 ATTENUATORS

Quam-Nichols Company

234 East Marquette Road, Chicago, IL 60637
Phone: (800) NEED NOW Fax: (888) NEED NOW
(800) 633 - 3669 (888) 633 - 3669
E-Mail: neednow@qnc.com www.quamspeakers.com

© 2011 Quam-Nichols Company Quam-Nichols reserves the right to make changes and/or improvements to its products at any time and without notice.



TQC20_11MR16