



Quam

CIS12/25

1-Gang, Vandal Resistant Call-In Station, with 25V Transformer, Stainless Steel

0602 - VANDAL RESISTANT INTERCOM ASSEMBLIES

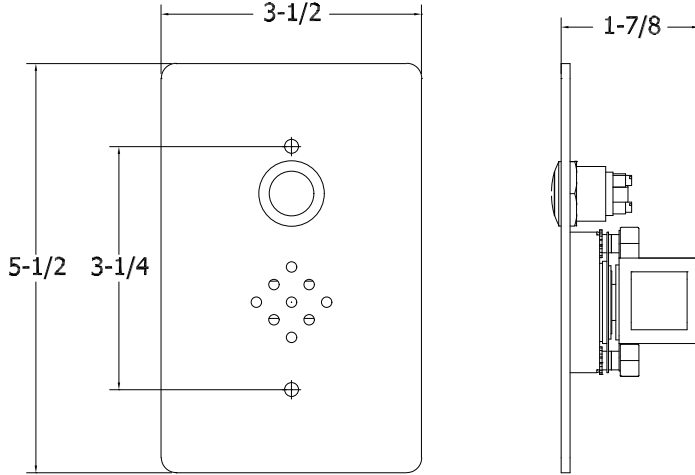

GENERAL DESCRIPTION

The Quam CIS12/25 is a complete vandal-resistant 1-gang call-in station with integral speaker/microphone, 25V transformer and momentary, normally open, push-to-call button. The faceplate is 12 gage, brushed stainless steel with tamper-resistant, #6-32 'pin-in-torx' hardware. An optional, red mushroom button can be substituted at extra cost at the time of order.

Other transformer and voice coil impedances options are available, please contact Factory.

INTENDED USE: All variants

Indoor or outdoor environment.

Program material: Signal tones and voice

SYSTEM COMPONENTS

Loudspeaker	Weather-resistant mylar cone
Transformer:	25V, 1W, 3 taps at -3 db levels

Recommended QUAM VANDAL RESISTANT Accessory MP1 Mounting Platform

AUDIO SPECIFICATIONS

Speaker Size	1.75"
Average Sensitivity	84 dB-SPL, 1W / 1M
Power rating	1W RMS, EIA 426A Standard
Frequency Response	250 - 6 kHz EIA 426A Standard
Nominal Coverage Angle	90° Included Angle
Audio Connection	-6 dB / 2 kHz, half space Transformer: 7" long, color-coded tinned wires, Pre-cut

Recommended construction sequences, installation instructions and A&E Specifications are available in various formats on the Quam Architects' and Engineers' Resources CD or on the web at: www.quamspeakers.com

CORRECTION / DETENTION

06

Quam-Nichols Company

234 East Marquette Road, Chicago, IL 60637
 Phone: (800) NEED NOW Fax: (888) NEED NOW
 (800) 633 - 3669 (888) 633 - 3669
 E-Mail: neednow@qnc.com www.quamspeakers.com

