



Quam

DTS1 Desktop Intercom Station, with Replaceable Gooseneck Mic

DTS3 Desktop Intercom Station, Less microphone

0602 - VANDAL RESISTANT INTERCOM ASSEMBLIES

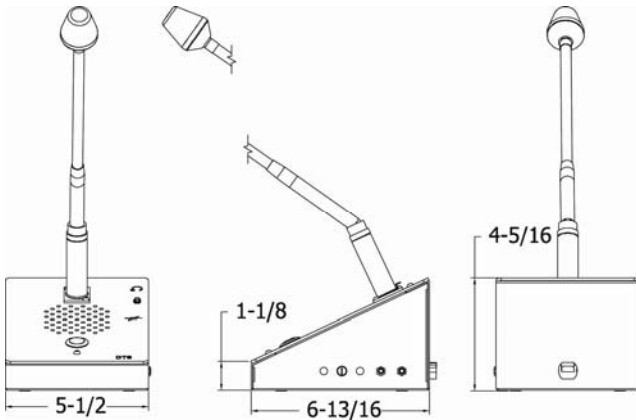

DTS1 Shown

GENERAL DESCRIPTION

The Quam DTSx desktop intercom station is a vandal-resistant, microphone / loudspeaker assembly with push-to-talk (PTT) button switch. Loudspeaker baffle is 12 gage, stainless steel with three (3) interwoven steel security screens mounted between the faceplate and the loudspeaker; enclosure is 16 gage CRS with 'pin-in-torx' hardware. Console finish: black baked epoxy hybrid finish.

DTS1: As above with replaceable 18" metal dynamic gooseneck microphone

DTS3: As above, less microphone

INTENDED USE

Indoor environment, simplex two-way communication using PTT microphone and internal, 'never full off' volume controlled, moisture-resistant loudspeaker.

Loudspeaker internally configured for either 8Ω or 25V systems. (2) 3.5mm input/output jacks allows use of low impedance computer style headset (not supplied), bypassing loudspeaker function. Pre-drilled holes in base for bolt-down applications.

Program Material: Voice and signal tones

SYSTEM COMPONENT

Loudspeaker	30C25Z80T
-------------	-----------

RECOMMENDED ADDITIONAL QUAM COMPONENTS

0602- Vandal Resistant Intercom Assemblies

AUDIO SPECIFICATIONS

DTS1 Microphone Type	Unidirectional Dynamic
Sensitivity	-76 dBV/Pa ±4dB ¹
Impedance	500Ω Nominal
Frequency Response	130-12kHz, ±3dB
Speaker Size	3" Frame loudspeaker
Average Sensitivity	87 dB, 1W/1M
Frequency Response	150-10KHz

¹ 0dB=1V/Pa, 1kHz

ELECTRICAL SPECIFICATIONS

Volume Control	-15 dB Maximum attenuation
Headset Jack	Two (2) 3.5mm, mono input/output, disconnects 'never full off' speaker output when activated
Electrical Connections	Internal barrier strip

Recommended construction sequences, installation instructions and A&E Specifications are available in various formats on the Quam Architects' and Engineers' Resources CD or on the web at: www.quamspeakers.com

CORRECTION / DETENTION

06

Quam-Nichols Company

234 East Marquette Road, Chicago, IL 60637
Phone: (800) NEED NOW Fax: (888) NEED NOW
(800) 633 - 3669 (888) 633 - 3669
E-Mail: neednow@qnc.com www.quamspeakers.com

