

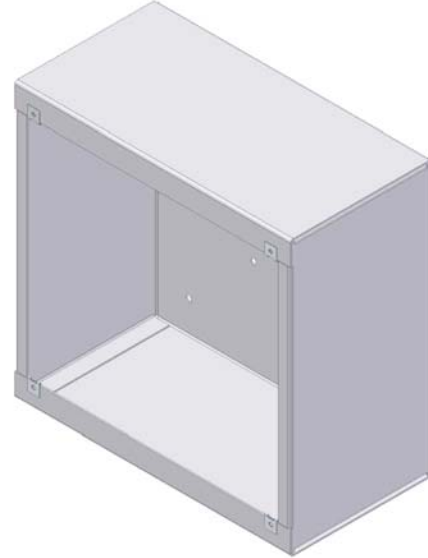

# Quam

## SE5WVP Vandal Resistant Loudspeaker Enclosure

### 0603 - VANDAL RESISTANT COMPONENTS

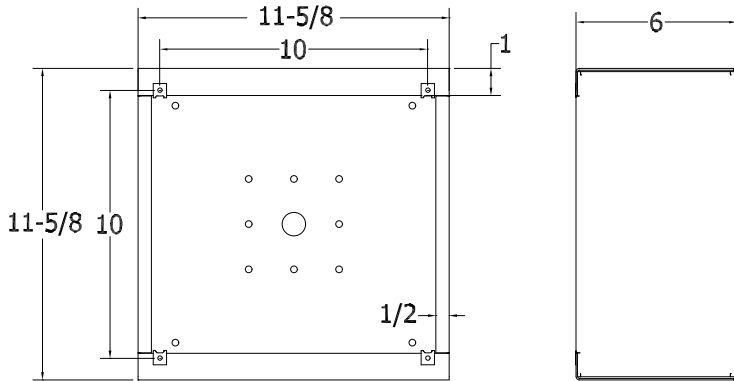

#### GENERAL DESCRIPTION

The Quam SE5WVP is a 16 gage steel, vandal-resistant loudspeaker enclosure.

Enclosure has 4x #8-32 threaded baffle mounting holes and 3/4" conduit entrance on the rear of the enclosure.

Finish: White baked epoxy hybrid

#### INTENDED USE

Protected outdoor or indoor environment

#### RECOMMENDED ADDITIONAL QUAM COMPONENTS

- 0103- Paging Horn  
H16/SVP 16W Paging Horn, 25/70V xfm with Vandal Resistant Baffle  
*-or following components-*
- 0204- Public Address Loudspeaker  
8C10PAOT- 8 Ohm, 10 oz. magnet, Moisture resistant
- 0502- Transformer  
(As required)
- 00603- Vandal Resistant Components  
BS8VP-Square, Vandal Resistant baffle for 8" frame loudspeaker

Recommended construction sequences, installation instructions and A&E Specifications are available on the web at: [www.QuamSpeakers.com](http://www.QuamSpeakers.com)

**06 CORRECTION / DETENTION**

#### Quam-Nichols Company

234 East Marquette Road, Chicago, IL 60637  
 Phone: (800) NEED NOW Fax: (888) NEED NOW  
 (800) 633 - 3669 (888) 633 - 3669  
 E-Mail: [neednow@qnc.com](mailto:neednow@qnc.com) [www.quamspeakers.com](http://www.quamspeakers.com)

