



Quam

SYSTEM 15

Tile Replacement Loudspeaker Assembly Extended Frequency Response

0104.5 - LAY-IN CEILING MOUNT (TILE REPLACEMENT)

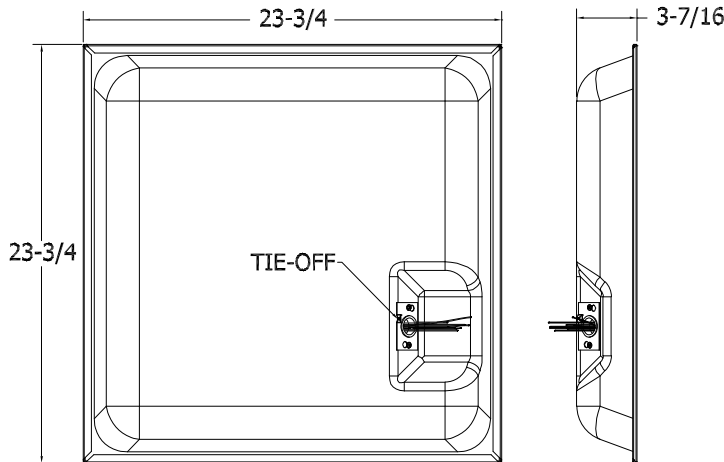

01

LOUDSPEAKER ASSEMBLIES

GENERAL DESCRIPTION

The Quam SYSTEM 15 is a complete loudspeaker assembly, with 8" frame, wide frequency response, coaxial loudspeaker, 70.7V transformer, perforated steel baffle and integral back box.

Finish options: White or black baked epoxy hybrid.

INTENDED USE

Mounted parallel to floor plane in a 24" wide suspended ceiling tile grid; indoor environment.
Program Material: Music, voice and signal tones

SYSTEM COMPONENTS:

Loudspeaker	8C10FECO
Transformer	TCH70,10W, 5 taps at -3dB levels, low-loss, extended LF
Finish options	Order as SYSTEM 15/B
Black only	

RECOMMENDED ADDITIONAL QUAM COMPONENTS

N/A

AUDIO SPECIFICATIONS

Speaker Size:	8" frame
Average Sensitivity:	97 dB-SPL, 1W/ 1M
Loudspeaker Power Rating:	20W-RMS, EIA 426A Standard
Calculated Output:	108 dB-SPL, 10W / 1M
Magnet Type, Weight	BeFe Ceramic, 10 oz. Nominal
Frequency Response:	40 - 20kHz EIA 426A Standard
Nominal Coverage Angle:	100° Included angle, -6dB 2 kHz, half space
Audio Connection:	7" long labeled, tinned wires, pre-cut

Recommended construction sequences, installation instructions and A&E Specifications are available in various formats on the Quam Architects' and Engineers' Resources CD or on the web at: www.quamspeakers.com

Quam-Nichols Company

234 East Marquette Road, Chicago, IL 60637
Phone: (800) NEED NOW Fax: (888) NEED NOW
(800) 633 - 3669 (888) 633 - 3669
E-Mail: neednow@qnc.com www.quamspeakers.com

